



FIT-1001-M LOOP POWERED AIR VOLUME/ VELOCITY INDICATING TRANSDUCER

DESCRIPTION

The **FIT-1001-M** airflow transducer is a combination differential pressure transmitter, square root extractor, scaling multiplier, and output filter with process indication; complete in a single package.

The differential pressure transducer sensor operates on the capacitance principal and is capable of sensing ultra low differential (velocity) pressures. In the capacitance cell, a very lightweight, responsive diaphragm deflects a small amount when pressure is applied. This deflection results in a change in capacitance, which is then detected and processed electronically into an output signal linear to the velocity pressure. The electronic signal is then sent to the square root extractor/multiplier, which converts the velocity pressure signal into an analog output linear to air velocity (fpm) and air volume (cfm).

The measured process air velocity/volume is independently indicated on a front panel mounted magnehelic pressure gauge scaled in both cfm and fpm. This independent readout allows for quick and immediate verification that the electronic transducer is operating effectively.

Each **FIT-1001-M** is selected and factory calibrated to meet the design requirement of the flow measuring element being served.

Features

- Two wire 4-20 mA output
- $\pm 1\%$ F.S. accuracy
- $\pm 0.5\%$ F.S. accuracy (optional)
- Square root extractor/multiplier
- Independent Indication of flow
- Full scale ranges as low as 1,266 fpm
- Can be operated continuously in temperature ranges of 32 to 160 °F
- Can be stored in temperature ranges of -40 to 180 °F
- Zero shift of only $\pm 0.025\%$ F.S. per °F
- Span shift of only $\pm 0.025\%$ F.S. per °F
- Differential overpressure of 5 psi proof and 25 psi burst
- Vibration less than 0.05% F.S. temporary effect with 5g's, 0-60 Hz
- Non-corrosive dry gas pressure media
- Pneumatic ¼" compression process input connection
- NEMA 1 rated enclosure

FIT-1001-M Technical Specifications

1. AVAILABLE FULL SCALE RANGES

No.	Velocity (fpm)
1	1,266
2	2,003
3	2,832
4	3,468
5	4,005
6	5,664
7	6,937
8	8,955
9	12,665

2. PROCESS INPUT CONNECTION

Pneumatic 1/4" compression, suitable for either hard or soft wall signal tubing

3. ENCLOSURE

NEMA 1, Aluminum

4. PRESSURE MEDIA

Non-Corrosive dry gases

5. OPERABLE LINE PRESSURE

< 0.5% F.S. @ 10 psi maximum static pressure

6. DIFFERENTIAL OVERPRESSURE

5 psi proof and 25 psi burst pressure

7. VIBRATION

<0.05% F.S. temporary effect with 5g's, 0-60 Hz

8. FULL SCALE ACCURACY DATA AT 70°F

	Standard	Optional
Combined accuracy	±1.00%	±0.50%
Terminal point nonlinearity	±0.80%	±0.40%
Hysteresis	±0.05%	±0.02%
Non-repeatability	±0.10%	±0.05%

9. ENVIRONMENTAL ATTRIBUTES

Storage	-40 ~ 180°F	-40 ~ 82°C
Operating	32 ~ 160°F	0 ~ 70°C
	(10-95% R.H. non-condensing)	
Compensation Range	40 ~ 125°F	4 ~ 52°C
Zero shift	±0.025%FS/°F	±0.025%FS/½°C
Span shift	±0.025%FS/°F	±0.025%FS/½°C

10. ELECTRICAL INFORMATION

Output	4 ~ 20mA (2 Wire)
Supply Power	18 ~ 36 VDC
	$V_{min} = 12 + (0.022 \times R_{LOAD})$
Connections	Screw Terminals
External Load	790 Ω max. @ 36 VDC

11. APPROXIMATE WEIGHT

3 LB

FIT-1001-M Ordering Information

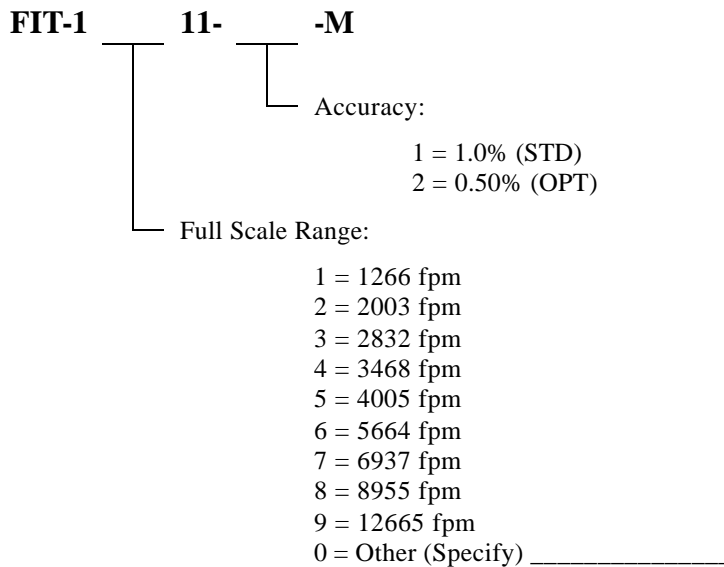

FIT-1001-M Dimensions

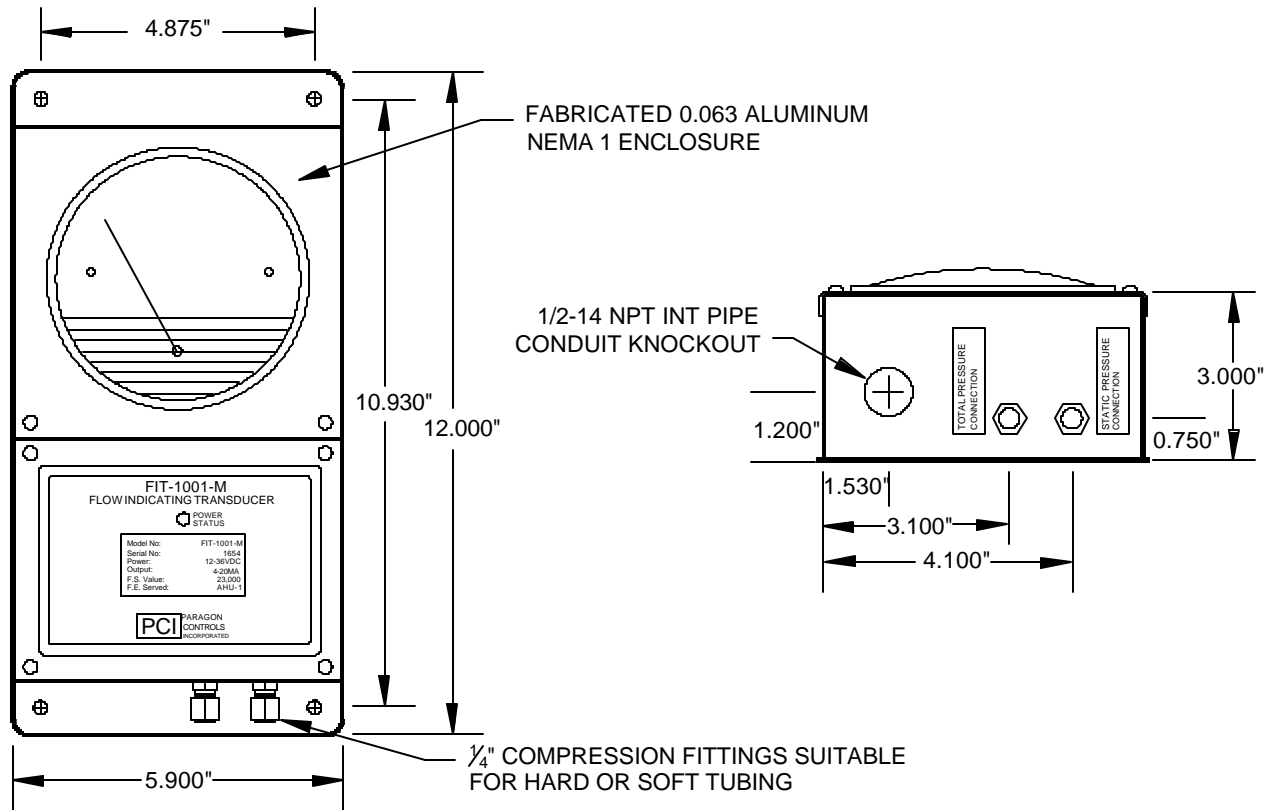

FIT-1001-M Field Connections and Load Limitations

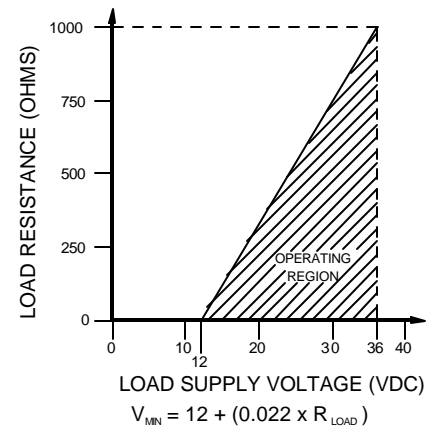
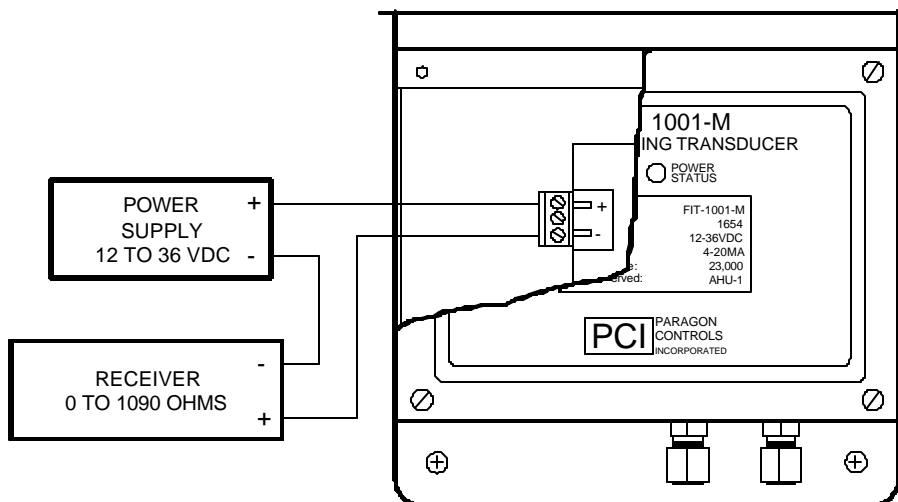

FIT-1001-M Specification Guide

Electronic Transducers

1. Provide individual airflow transducers selected for the required design airflow rate of the primary element served. Each transducer shall be selected for its respective duty. Supply, Exhaust and/or Return Airflow Transducers shall provide analog output signal linear to air volume that are factory set for a full scale value equal to 110% of the maximum design capacity of the airflow measuring element served for variable air volume applications, or 200% of the design operating value for constant volume applications.
2. The transducer(s) shall be solid state electronic type, with infinite output resolution, capable of performing dedicated air volume measurement and indication functions. Microprocessor based transducers with time sharing of multiple square root extractors and/or controllers are not acceptable.
3. Each transducer's output shall not be affected by direction of mounting (attitude) or external vibrations, and shall be furnished with a factory calibrated span that matches the application.
4. Airflow transducers shall be provided with an integral dual scale indicating meter operating independent of all other control devices. The top scale shall indicate the measured air volume in units of cubic feet per minute (CFM), and the bottom scale shall indicate the air velocity in units of feet per minute (FPM). The meter shall be calibrated to an accuracy of $\pm 2\%$ of span ($\pm 3\%$ of span for 0.5 inch water column magnehelic gauge or $\pm 4\%$ of span for 0.25 inch water column magnehelic gauge).
5. Transducer performance shall be equal to or better than the following:
Accuracy: 0.5% F.S. (Terminal Point) / 0.35% F.S. (BFSL)
Temperature Effects: $<0.03\%$ F.S./ $^{\circ}\text{F}$
Over-pressure: 5 PSIG Proof / 10 PSIG Burst
Response: <0.25 seconds for full span input
Noise Filtration: Low Pass Filter, factory set @ 3.2Hz

Labeling

1. An identification label shall be placed on each airflow indicating transducer listing the model number, airflow measuring elements served, full scale value, and identifying tag number.

Manufacturer

1. Electronic transducers with independent flow indication shall be Paragon Controls Inc. Model FIT-1001-M or equal as approved by the Engineer.
2. Naming of a manufacturer does not automatically constitute acceptance of this standard product nor waive the responsibility of the manufacturer to comply totally with all requirements of the proceeding specification.